

# MARINE

## Marine



Pilgrim International Limited  
Southlink, Oldham OL4 1DE, UK  
Tel: +44 (0) 161 785 7700  
Fax: +44 (0) 161 785 7777  
Email: [sales@pilgrim-international.co.uk](mailto:sales@pilgrim-international.co.uk)  
[www.pilgrim-international.co.uk](http://www.pilgrim-international.co.uk)

**PIONEERING COUPLING TECHNOLOGY**  
Faster to install, safer and easier to handle  
Major life cycle benefits

# THE WORLD'S MOST ADVANCED PROPULSION SHAFT COUPLING SOLUTIONS



**Pilgrim Radial Fit Bolts**  
Can be installed in 10-15 minutes  
and removed just as quickly

An innovative alternative to traditional shrink-fit bolts

Faster to install and remove

Safer and easier to handle - no bolt freezing

Significantly lower life cycle costs

Last the complete life of the vessel

No re-machining

Newbuild or direct retrofit

Reliability means more effective planning

OEM approval



*VLCC with ABS Classification installed  
with Pilgrim Radial Fit Bolts at the engine  
to 1st intermediate coupling flange*

The product of more than forty years of development and innovation, Pilgrim Radial Fit Bolts utilise hydraulically-induced mechanical expansion to deliver significant benefits over conventional shrink-fit bolts.

Used extensively throughout the world by the marine, power and oil industries, our coupling bolt systems are backed by the most stringent quality control procedures and the highest standards of service.

Whatever the application, we have the skills and resources to design, manufacture and supply solutions that are at the very forefront of coupling technology.

- > Radial Fit Bolts
- > Morgrip bolt
- > Other bolting solutions
- > Hydraulic nuts
- > Marine ringjacks
- > Oil injection systems
- > Hydraulic pumps (hand and air driven)
- > Full range of support services

# THE PROBLEMS ASSOCIATED WITH TRADITIONAL SHRINK FIT BOLTS

- Varied and inaccurate interference levels
- Varied and inaccurate clamping forces
- Bolt holes often damaged on removal
- Bolts often destroyed during removal
- Can be hazardous to handle
- Difficult to plan the engineering time and resources
- High potential for operating delays
- Recurring problems – whenever shrink fit bolts are removed and re-installed



Damaged shrink fit bolt after removal



Example of the problems that can occur using shrink fit bolts

Traditional shrink fit bolts are manufactured with an outer diameter that is larger than the coupling hole. This means they first have to be frozen in liquid NO<sub>2</sub> or dry ice and alcohol until the outer diameter reduces sufficiently to allow the bolt to be inserted in the hole.

As the shrink fit bolt returns to its normal temperature it expands back to its normal size. The result: an interference fit is formed.

Installation of shrink fit bolts can be difficult and at times hazardous. With a typical clearance condition of 0.01mm to 0.04mm, internal alignment of the bolt has to be perfect otherwise the bolt can become stuck or only partially inserted into the hole - a frequent occurrence.

Removal of shrink fit bolts during a tailshaft survey, bearing inspection or general shaft maintenance programme can be equally problematic, with many bolts breaking. When this happens, the bolts have to be drilled out and the holes re-bored, honed and made ready to receive new bolts.

As a 'critical pathline' component, operational delays often occur as a result of shrink fit bolt problems. New bolts have to be sourced and modified drawings have to be approved by Class – resulting in a costly process that can lose hundreds of thousands of dollars per year across a fleet.

This can be avoided by using Pilgrim's advanced coupling bolt technology.

# THE INNOVATIVE, TECHNICALLY PROVEN SOLUTIONS DEVELOPED BY PILGRIM

Installed at the face-to-face coupling flanges used to connect the different sections of the propulsion shaft, Pilgrim Radial Fit Bolts are fitted and removed in just ten – fifteen minutes. The complete installation and removal processes are extremely reliable and predictable, allowing resources and engineering time to be accurately forecast.

Unlike traditional bolts, Pilgrim Radial Fit Bolts are not over-sized – they fit in the hole, no shrinkage is necessary. As will be appreciated, this is a huge advantage.

The Radial Fit Bolts themselves consist of a tapered bolt and an internally tapered sleeve. When the bolt is hydraulically pulled into the sleeve, the outer diameter of the sleeve is forced to expand inside the hole and form a pre-engineered interference/pressure fit. The bolt is then hydraulically tensioned to provide a pre-determined secure clamping force, pulling the two flanges together.



# ENGINEERING LIFE CYCLE COST COMPARISON

Engineering life cycle costs comparing the use of Pilgrim Radial Fit Bolts with traditional shrink fit bolts.

Class required 'Tailshaft Surveys' every five years.

**Case example:** Installation to an Aframax tanker, at both the 'Eng to Int' and 'Int to Prop' flanges, with 12 bolts fitted to each coupling flange.

Over a twenty-year period the estimated saving to the ship owner/manager is in the region of US\$70,000. *This excludes the loss of operating time and subsequent loss of revenue.*

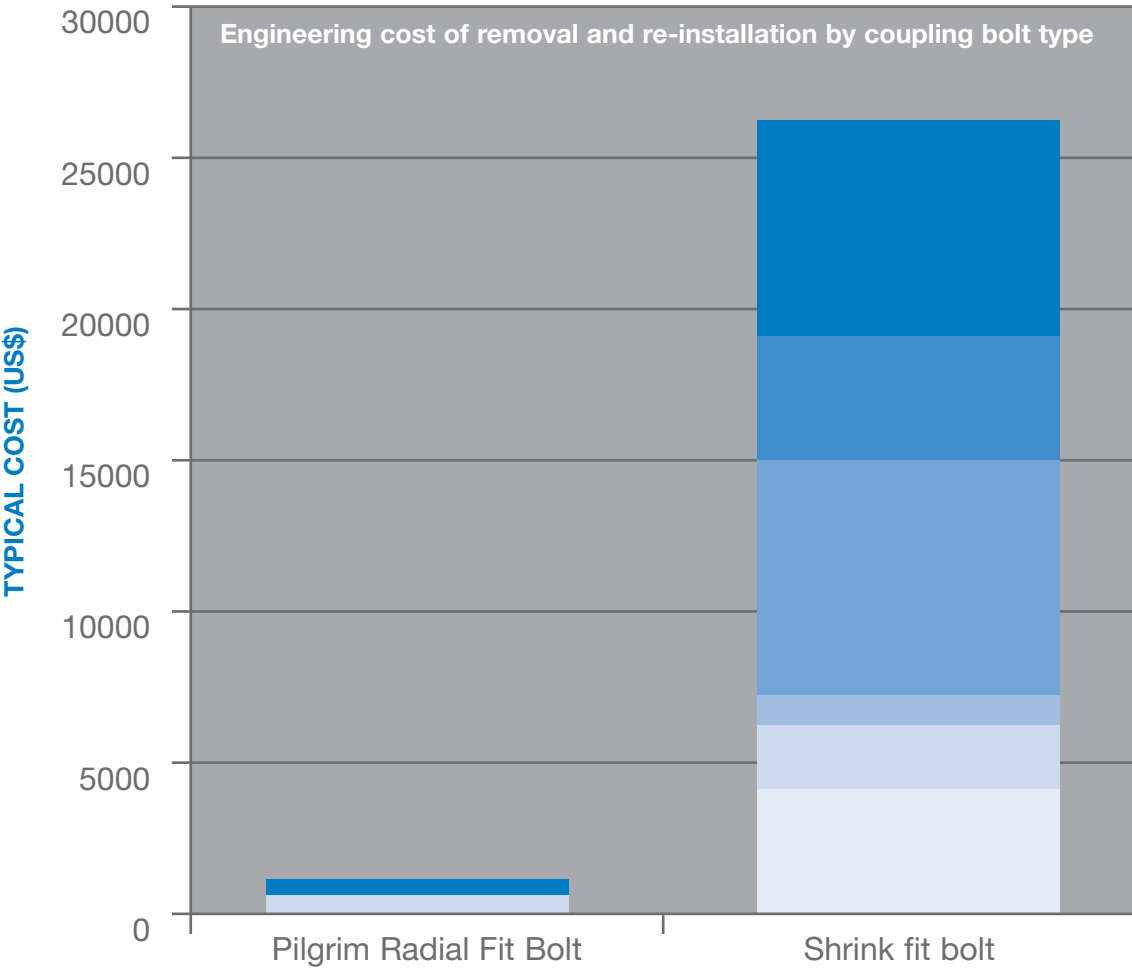

	Pilgrim Radial Fit Bolt	Shrink fit bolt
Bolt removal time for 24 bolts at US\$200/hr	400	7200
Hole re-bore at US\$200/hole	0	4000
New Bolts	0	8000
Class Costs	0	1000
Freezing at US\$ 100/bolt	0	2000
Installation time for 24 bolts at US\$200/hr	600	4000

### ADVANTAGES TO SHIP YARDS

- > Faster installation
- > Less hazardous – no freezing, easier handling
- > Easy removal and re-installation to correct shaft line mis-alignment
- > Accurate, secure pre-engineered interference fit and clamping loads across flanges



### ADVANTAGES TO SHIP OWNERS

- > Faster tailshaft surveys
- > Fully re-usable for entire life of vessel
- > Virtually eliminates the need for secondary engineering to the shaftline



### ADVANTAGES TO SHIP MANAGERS

- > Operating time maximised
- > Virtually no need for secondary engineering
- > Reduced maintenance budget
- > Eliminates the difficulties associated with bolt removal
- > Makes planning of central docking schedules easier
- > Accurate, secure, pre-engineered interference fit and clamping loads across flanges



# PILGRIM RADIAL FIT BOLTS

## INSTALLATION SUMMARY

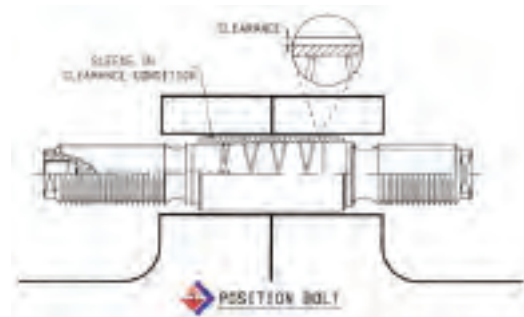

### INSERTION OF THE BOLT

The Pilgrim Radial Fit Bolt assembly is composed of a tapered bolt, an internally tapered sleeve, and two securing nuts. When the sleeve is placed over the tapered bolt, the resulting OD is less than that of the coupling hole (clearance condition). For a coupling hole dia 100.00mm hole, a typical clearance condition would be 0.12mm making the RFB very easy to insert into the coupling hole.

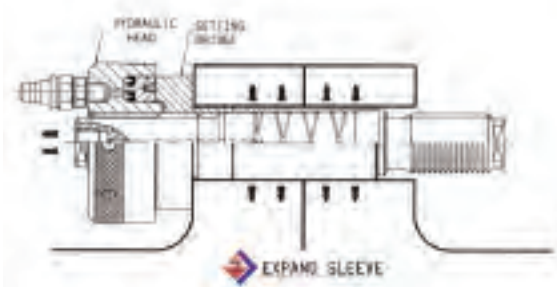

### SETTING THE SLEEVE

The setting bridge is placed over the end of the bolt and is firstly used to locate the position of the sleeve within the coupling hole. The setting bridge then holds the sleeve in position whilst the hydraulic head 'draws/pulls' the bolt into the sleeve. As the bolt is drawn into the sleeve, the OD of the sleeve is forced to increase. Firstly occupying the clearance condition within the hole and then exerting a pressure inside the coupling hole along the entire contact area between the sleeve and the hole.

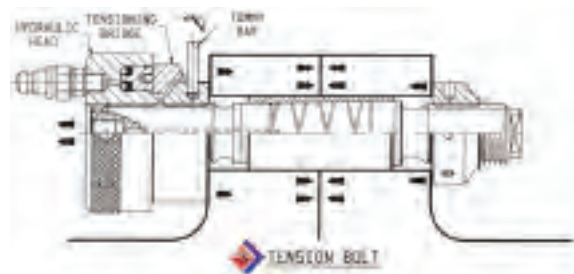

### TENSIONING THE BOLT

After setting the sleeve, the securing nuts are fitted to both ends of the RFB assembly, and tightened firmly by hand. A tensioning bridge is then used to bridge over the nut, from the same end at which the sleeve was set. A hydraulic force is introduced using the hydraulic head, and whilst under load the nut under the tensioning bridge is tightened using a tommy bar. Once tightened, the pressure can be released and both the tensioning bridge and hydraulic head are removed, and the RFB assembly is now fully installed.

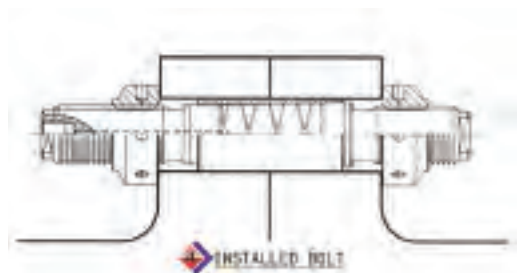

## REMOVAL SUMMARY

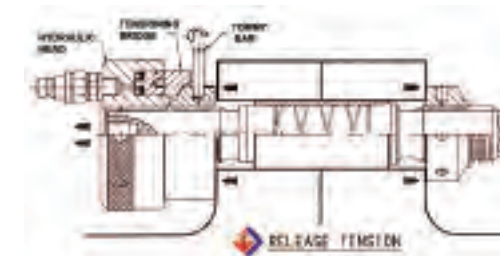

### DE-TENSIONING THE BOLT

The tensioning bridge is fitted over the same nut, which was tightened during the tensioning of the bolt. A hydraulic force is introduced using the hydraulic head. Whilst under load, the nut under the tensioning bridge is released 2 full turns using the tommy bar. After which, the pressure can be released and both the tensioning bridge and hydraulic head can be removed.



### OIL INJECTION

The oil injection adaptor is screwed into the oil injection port on the Radial Fit Bolt, and tightened firmly. A suitable hose and oil pump is then connected to the oil injection adaptor. Increasing oil pressure is then introduced into the Radial Fit Bolt assembly until the sleeve and bolt separate. After the release occurs the hydraulic hose and pump can be disconnected. The oil injector removed. Both securing nuts on the Radial Fit Bolt assembly can be removed.



### WITHDRAWAL OF THE BOLT

After oil injection the original clearance condition between the coupling hole and the sleeve returns. The Radial Fit Bolt and sleeve can now be easily withdrawn from the coupling hole.

The coupling hole, Radial Fit Bolt and sleeve are completely undamaged and can be re-installed.

# GENERAL TECHNICAL INFORMATION

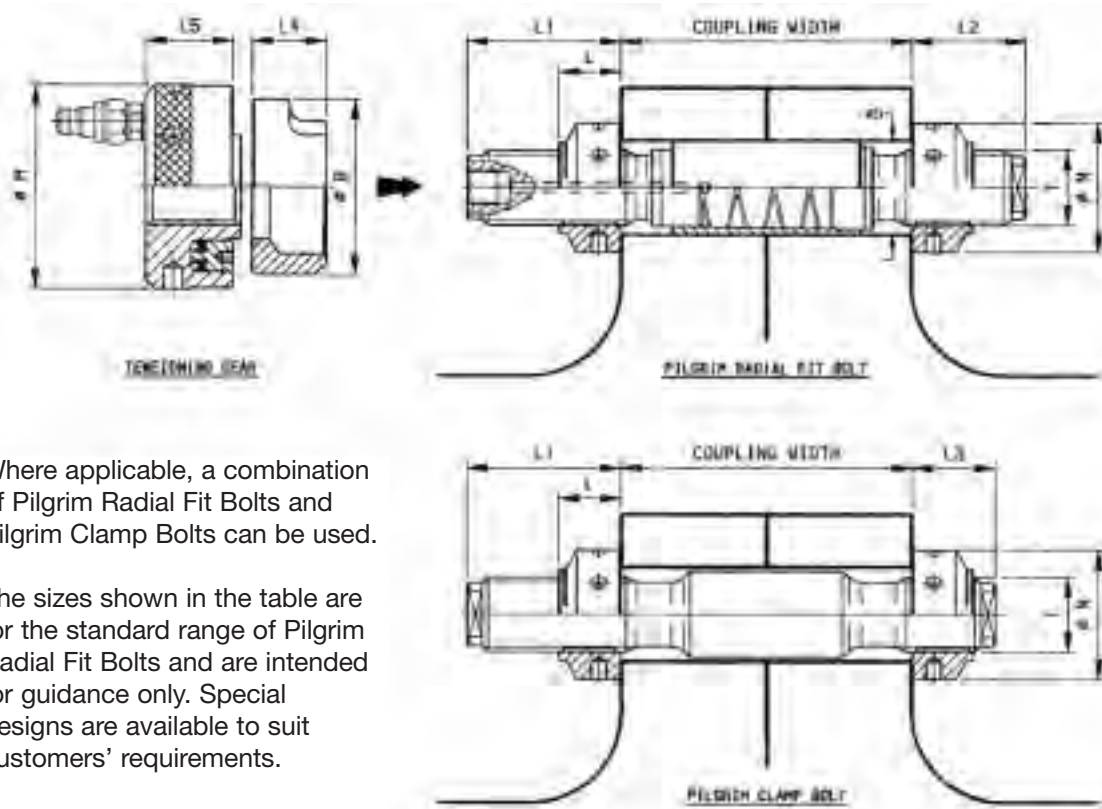

Where applicable, a combination of Pilgrim Radial Fit Bolts and Pilgrim Clamp Bolts can be used.

The sizes shown in the table are for the standard range of Pilgrim Radial Fit Bolts and are intended for guidance only. Special designs are available to suit customers' requirements.

Nom.Hole Diameter D	Thread T	Nut Dia Ø N	Nut Height L	Bolt Stand Outs				Tensioning Gear			Max Applied Axial Load KN
				L1	L2	L3	L4	L5	Ø M	Ø B	
40 - 44	M 33 x 3.5	58	27	68	52	38	32.0	39	90	83.0	308
45 - 47	M 36 x 4	63	29	73	55	41	34.5	42	98	89.0	360
48 - 51	M 39 x 4	67	32	79	60	44	38.0	45	106	92.0	435
52 - 54	M 42 x 4.5	72	34	84	63	46	40.5	48	113	98.0	500
55 - 58	M 45 x 4.5	76	36	89	67	48	42.5	50	120	104.5	588
59 - 63	M 48 x 5	82	39	97	73	54	46.5	52	127	111.5	660
64 - 68	M 52 x 5	89	42	104	78	57	50.0	54	137	120.5	795
69 - 72	M 56 x 5.5	96	45	111	83	60	53.5	55	147	129.5	924
73 - 78	M 60 x 5.5	102	48	115	88	63	57.0	56	158	139.0	1078
79 - 83	M 64 x 6	109	52	123	94	68	61.5	58	166	147.5	1210
84 - 87	M 68 x 6	116	55	130	99	71	65.0	61	177	157.0	1390
88 - 93	M 72 x 6	122	58	137	104	74	68.5	64	187	166.0	1585
94 - 97	M 76 x 6	130	61	144	109	77	72.0	67	197	176.0	1790
98 - 103	M 80 x 6	137	64	152	116	82	76.0	70	208	185.5	2008
104 - 109	M 85 x 6	147	68	161	123	86	80.5	74	220	198.5	2298
110 - 116	M 90 x 6	155	72	170	129	90	85.0	78	232	209.5	2610
117 - 121	M 95 x 6	164	76	179	136	94	90.0	82	245	222.5	2938
123 - 129	M 100 x 6	172	80	187	142	98	94.5	86	258	234.0	3295
130 - 135	M 105 x 6	182	84	199	152	105	99.5	89	270	246.5	3656
136 - 140	M 110 x 6	190	88	208	158	109	104.0	92	283	258.0	4050
141 - 146	M 115 x 6	199	92	217	165	113	109.0	95	295	270.0	4450
147 - 150	M 120 x 6	208	96	225	171	117	113.5	98	309	282.0	4880

All dimensions shown in millimetres

## Helical oil grooves

To facilitate easy removal by oil injection, the body of the Pilgrim Radial Fit Bolt is machined with twin helical grooves. These allow the oil to distribute freely and quickly between the mating surfaces of the bolt and the sleeve to achieve efficient separation – the most effective way of producing an even interface pressure that ensures the bolts can be taken out smoothly and quickly.

## Hardened taper sleeve

The tapered sleeves are surface hardened to provide a predictable coefficient of friction between them and the bolts, improving resistance to corrosion and allowing the sleeve to be removed from the bolt more efficiently.

The non-metallic nature of the compound zone formed on the surface of the sleeve eliminates pick-up and prevents bolt seizure. When oil is introduced during the removal process, the coefficient of friction is reduced to ensure fast and efficient separation of bolt and sleeve.

## Bolt tensioning kit

These can be single or dual operated. They include all of the necessary components for fast installation and removal. The dual kit allows two bolts to be pressurised simultaneously, further reducing the assembly and removal time.



## Bolt removal by oil injection

This entails injecting oil under pressure between the interface of the bolt and the sleeve by means of an adaptor that locates into the bolt end. The adaptor is supplied with a lens ring, hardened for maximum life, ensuring the high pressure connection is sealed effectively and with the minimum physical effort. The lens also eliminates the possibility of damage to both the adaptor and injection port.

## Mechanical removal

An alternative mechanical removal facility is provided with all bolts. Its design allows removal by oil injection or mechanical means to be undertaken either simultaneously or individually.

## Material specification

All components of Pilgrim Radial Fit Bolts and bolt tensioning kits are manufactured from Ni Cr Mo alloy steels.

## Sizes

All Radial Fit Bolts are on a 'made to order' basis, designed to the exact bespoke requirements of the coupling flanges into which they will be installed.

## Quality

Pilgrim International Limited operates a quality control system that conforms to BS-EN-ISO 9001:2000. The system is regularly audited by an approved accreditation company.

## Inspection and testing

The design, materials and finished product are comprehensively tested and proven by our engineers and relevant Classification Society before despatch.

## Safety

All Pilgrim Radial Fit Bolts and ancillary equipment are designed for safe and simple use. The ease of bolt installation and removal eliminates many of the traditional, unsafe working practices often undertaken when using conventional bolts.

# MORGRIP MARINE BOLT



**A hydraulically actuated bolt designed to provide fast, cost-effective and trouble-free installation and removal.**

The Morgrip provides a stark contrast to the installation of traditional shrink fit bolts, which often cause scoring of both the hole and the bolt surface. The Morgrip bolt, on the other hand, can be repeatedly installed and removed quickly without damage to either the bolt or the hole.

The principle on which the bolt works is based on Poisson's ratio, which establishes that when a round steel component is stretched within its elastic limit, its diameter will reduce by a known amount.

The principle and design of the Morgrip bolt is universally accepted and approved by all major classification societies.

## BENEFITS

- Cost effective
- Approved
- Fast installation
- Reliable
- Custom design
- Easy removal



## INSTALLATION AND REMOVAL

**The stretching force is applied through a hardened steel rod located down the centre of the bolt. Operating gear is screwed on to the head of the bolt. When pressurised, this exerts a force through the rod to stretch the bolt. As the bolt stretches in length it contracts in diameter according to Poisson's ratio.**

Once pressurised, the bolt can be clearance installed in the hole. A nut is attached (if a through-hole application) and nipped tight. The pressure is then released to bring about a reduction in the length of the bolt and a corresponding increase in its diameter.

The reduction in length achieves an axial clamping load as the increase in diameter simultaneously achieves a fitted condition. The bolt is now ready for service. It can be installed remotely from the pump unit by using the stop valve fitted to the operating gear to lock in hydraulic pressure. Removal is the reversal of this procedure.



# MARINE HYDRAULIC NUTS



**Large Pilgrim Nut:** standard sizes PN1 to PN22 (200 to 752mm) bore. Special designs also available.

**Pilgrim Nut Shim Type:** standard sizes M36 to M220. Special designs also available.

**Pilgrim Nut LRL (Locking Collar) Type:** standard sizes M36 to M100. Special designs also available.

**Specials can be designed with:**  
Modified ports, special materials, special coatings / platings, high pressure applications, modified nut body, modified threads, modified load rings.

**The Pilgrim hydraulic nut has become the marine industry standard for fitting propellers, providing a quick, safe and cost-effective installation solution. It is also used extensively for tiller, rudder and stabiliser applications where precise high loading is required.**

The hydraulic pressure required by the Pilgrim nut is provided by the Morpress 10 pump. When the pressure is applied, the piston of the Pilgrim nut extends, pushing the propeller or rudder along the tapered shaft. The applied

pressure and travel of the piston correspond to the required push-up distance of the application.

As well as by oil injection techniques, removal of propellers and rudders can be simplified by reversing the Pilgrim Nut and using Pilgrim withdrawal equipment to pull the propeller or rudder off the taper.

The design principle of the Pilgrim Nut is universally accepted and approved by all major classification societies.

# MARINE RINGJACKS

Propeller and rudder applications

**The Pilgrim hydraulic ringjack has been designed and developed to facilitate the smooth assembly of taper mounting propellers, tillers, pintles and rudderstocks. It is of robust construction and incorporates a high pressure sealing system.**

The ringjack's compact design is suitable for mounting on to the screwed nut of a typical propulsion or steering assembly to provide axial push-up and final positioning. The Morpress 10 pump is the ideal means of providing the hydraulic pressure required by

the ringjack. When hydraulic pressure is applied, the piston of the ringjack extends, in the process pushing the propeller or rudder along the tapered shaft. The applied pressure and travel of the piston corresponds to the required push-up distance of the application.

The Pilgrim ringjack can be supplied either plain bored or threaded and designed to suit the dimension requirement of customers. The standard range of sizes incorporates 245mm to 720mm bore.

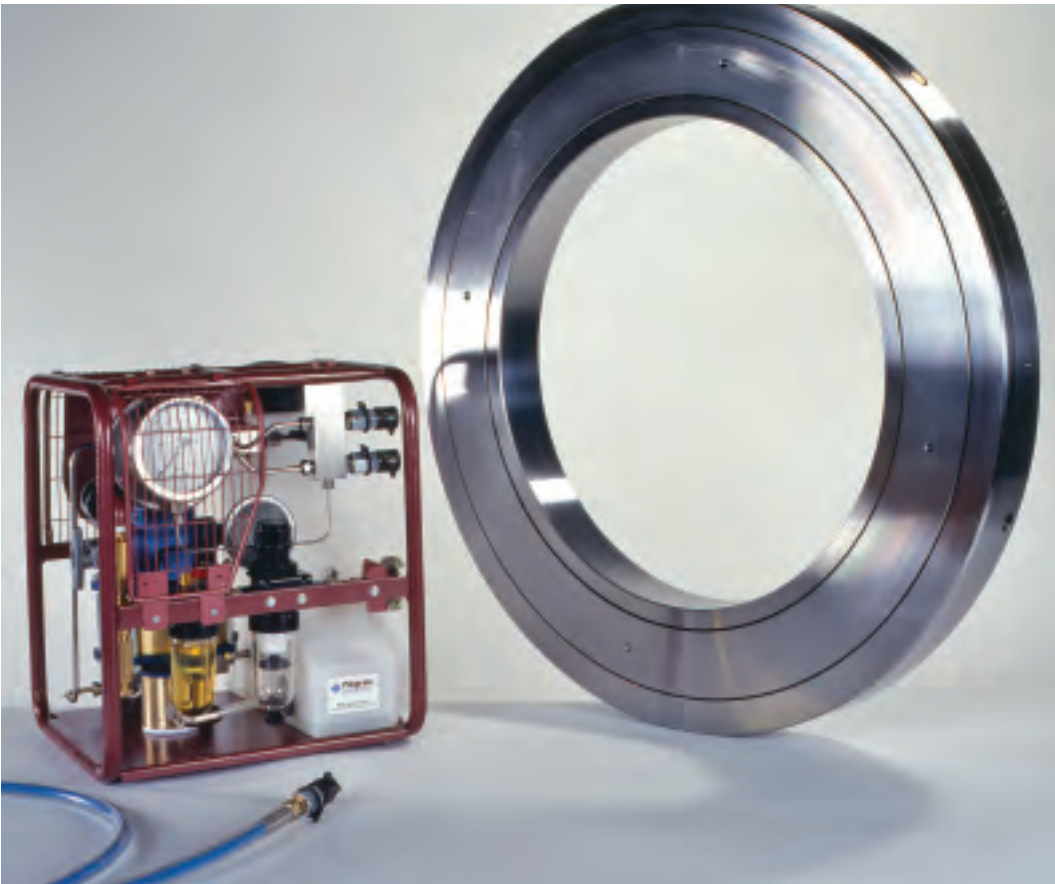

- BENEFITS**
- Compact**
- Reliable**
- Approved**
- Adaptable**
- Precise**
- Support**
- Robust**

# HYDRAULIC PUMPS

## MK10 MORPRESS AIR DRIVEN PUMP



### TECHNICAL SPECIFICATION:

	Model 525	Model 535	Model 620	Model 640
Hydraulic Output Pressure	0-1700 bar 0-25000psi	0-3000 bar 0-40000 psi	0-1700 bar 0-25000 psi	0-3500 bar 0-50000 psi
Pressure gauge rating will vary according to customer requirements.				
Approx weight with empty oil tank	21.0 kg	21.25 kg	25.2 kg	27.0 kg
Overall dimensions	380mm x 360mm x 440mm		15ins x 14.2 ins x 17.3 ins	
Reservoir capacity	8 litres	1.8 gallons (imp)		

**Lightweight, efficient, compact and easy to operate, the Morpress 10 provides instant and totally reliable hydraulic power.**

The pump utilises a low pressure air supply to generate a high pressure output. This is achieved by means of a simple differential area system in which a large area air piston at low pressure produces high pressure on a small hydraulic piston.

Simple air controls enable the Morpress 10 to provide any intermediate pressure required within the limits of the pump outage range.

Both oil and air are filtered prior to entering the system. The Morpress 10 requires only two connections, one to the air supply, the other to the hydraulic output. Simple and safe quick release couplings and high pressure flexible hoses are used to connect the equipment being used.

## HIGH PRESSURE HAND PUMP

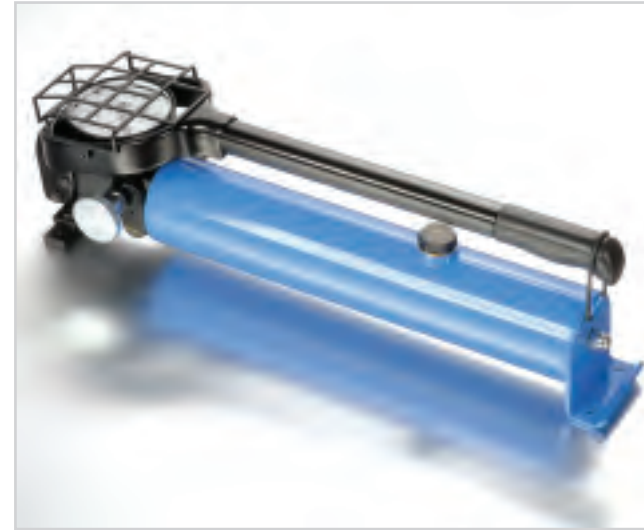

### TECHNICAL SPECIFICATION:

	1600 Bar	2400 Bar
Safe working capacity	1600 bar	2400 bar
Oil tank capacity	2.10 L	2.10 L
Usable Oil	1.7 L	1.7 L
Output per stroke	20/0.8 cm <sup>2</sup>	20/0.8 cm <sup>2</sup>
Weight	10 kg	10 kg

## Made to order

The Morpress 10 can be built to your specification. Lower or higher pressure models, special outlet arrangements and customised gauges can all be accommodated. Just let us know your exact requirement.

The standard Morpress 10 comprises an air pressure regulator, air pressure gauge, air filter/lubricator on/off control valve, oil reservoir, SC air/oil intensifier unit, oil return to tank valve, pressure relief safety valve and oil pressure gauge with damping facility.

## OIL INJECTION SYSTEM USING MODIFIED MORPRESS 10 PUMP

Easy to operate, robust and highly cost effective, the Pilgrim oil injection package is a complete system for the installation or removal of a propeller or rudder. Generally used with Pilgrim nuts or ringjacks, the system comprises a modified Morpress 10 air driven hydraulic pump incorporating two hydraulic outlets and gauges, flexible hoses and self-sealing quick release couplings.

The pump generates a controlled hydraulic pressure to the Pilgrim nut or ringjack while injecting oil to the tapered shaft interface of the propeller or rudder. The use of this oil during installation ensures that components are mounted and secured quickly and with total reliability.

Versatile and incorporating built-in safety features, the pump has an outstanding track record of accuracy and dependability.

### INSTALLATION AND REMOVAL

The time it takes to remove a propeller or rudder is greatly reduced by the Pilgrim oil injection package. An extensive range of other oil injection packages is also available using both Morpress 10 air driven pumps and Pilgrim hand pumps. Get in touch for details.

### TYPICAL PILGRIM OIL INJECTION PACKAGE

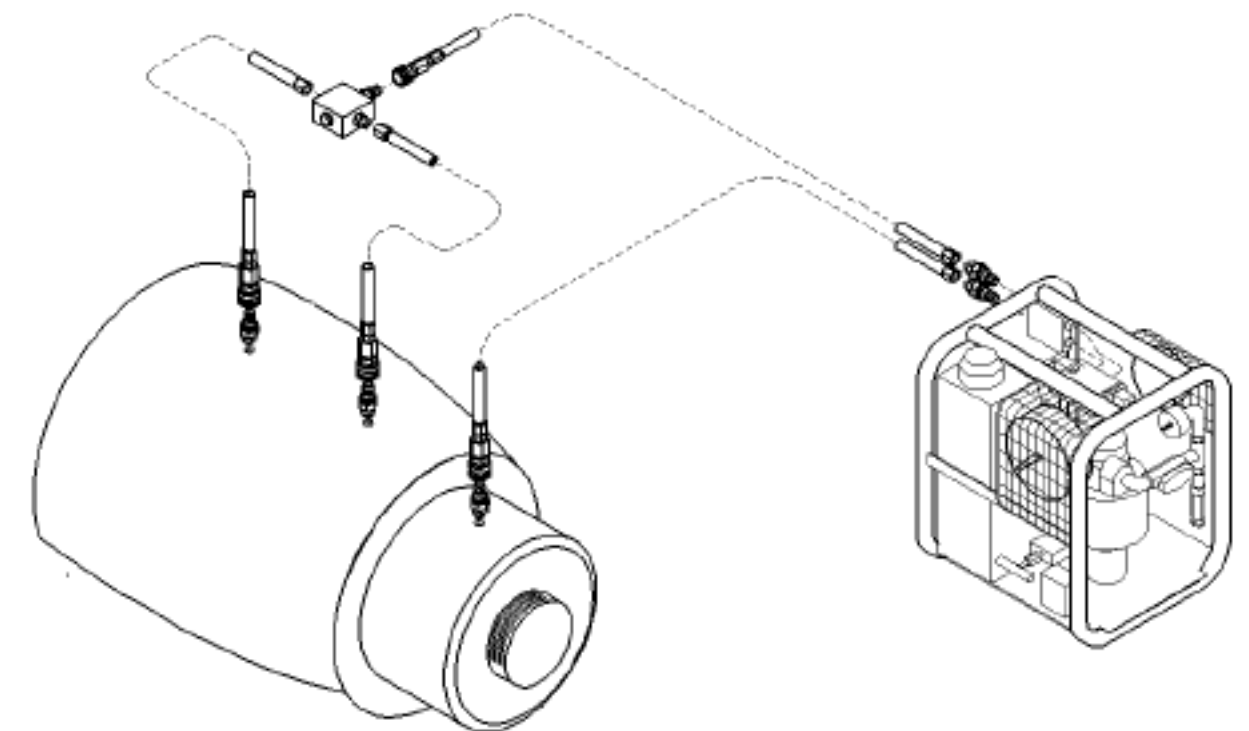

*Morpress pump with twin hydraulic outlets*

# TECHNICAL SUPPORT

Pilgrim provide a complete range of technical and training services. These include on-site installation support, comprehensive installation manuals and spare parts either from stock or with very fast delivery times.

Our reputation for safety and reliability, built up over many years, is the result of the integrity of our bolts and components and the thoroughness of the assistance and guidance we offer to both managers and installers. At every stage of a project we ensure that you have all of the help you need.

To maintain the smooth and continuous operation of essential equipment, we recommend and undertake in-house refurbishment of all tooling including complete bolt tensioning kits, hydraulic heads and air-operated pump units.



## ABACUS TRAINING KIT



The Abacus Training Kit has been developed to provide vital knowledge of Pilgrim Radial Fit Bolt installation and removal techniques without having to access the shaftline itself.

Suitable for use in both training facilities and workshops, the kit quickly instils confidence and understanding of essential procedures. It is ideal for either refresher or pre-installation training, where it ensures that everything runs smoothly during work on the actual shaftline.

Lightweight and easy to handle, the kit comprises a Pilgrim Radial Fit Bolt assembly, a steel block with a hole to simulate the coupling hole, a complete bolt tensioning kit and a high pressure hand pump.



*Pilgrim can arrange on-site training using our comprehensive demonstration kit. This is delivered by qualified engineers in either the workshop or a training facility.*

### CLASSIFICATION SOCIETIES

BV	BUREAU VERITAS
LR	LLOYDS REGISTER
ABS	AMERICAN BUREAU of SHIPPING
DNV	DET NORSKE VERITAS
GL	GERMANISCHER LLOYD
RINA	REGISTRO ITALIANO NAVALE
CCS	CHINA CLASSIFICATION SOCIETY
NKK	NK NIPPON KAIJI KOYOKAI
KR	KOREAN REGISTER of SHIPPING

### VESSEL TYPE

LNG CARRIERS
LPG CARRIERS
PRODUCT TANKER
OIL TANKER
CONTAINER VESSELS
CUTTER DREDGER
BULKERS
CHEMICAL CARRIER
PASSENGER / VEHICLE FERRY
RORO
AIRCRAFT CARRIER
SUBMARINE
FRIGATE
CRUISE LINERS

## INSTALLATION REFERENCES

**Safety and reliability that have been proven over many years in countless installations throughout the world**

Tel: +44 (0) 161 785 7700  
 Fax: +44 (0) 161 785 7777  
 Email: [sales@pilgrim-international.co.uk](mailto:sales@pilgrim-international.co.uk)  
[www.pilgrim-international.co.uk](http://www.pilgrim-international.co.uk)